



# chant™ Door Machining Equipment Trolley 6000

The chant™ Door Machining Equipment Trolley complete with jigs and accessories is a fully integrated door machining system. Designed for the professional installation of mortise locks, tubular latches, privacy bolts, slide bolts, flush pulls, and a variety of other door hardware, either on site or in the shop. While not possible to store all of our accessory jigs on the trolley at one time, there is generally room for the jigs for the project in hand.

To view a video of our door mortising equipment, please visit our website: [www.chantintouch.com](http://www.chantintouch.com)

Using this equipment ensures efficient, accurate and best practice standards required for fastidious customers. The typical time to machine a door to fit an average mortise lock to the point of being able to attach door handles is approximately 6 to 7 minutes.

This range of door machining equipment has evolved over many years to assist the installers of door hardware. The equipment is being successfully used by:

- Building contractors
- Interior fit out and partitioning contractors
- Locksmiths
- Door manufacturers
- Joiners
- Card access lock suppliers and installers:

The chant™ Equipment Trolley is often transported to distant sites to streamline installation. It is ideal for retrofitting and upgrading locks when dust collection is critical.

- Hardware merchants and distributors who provide a 'one stop' supply and installation service:

A single supply and installation contract often is the desired solution for customers, eliminating 'issues' and disputes arising from separate supply and installation contracts. However, this does require the supplier to invest in, and develop a professional team of competent hardware installers.

## Features

- The trolley is designed for the easy and convenient storage of everything needed to properly machine doors, and for the efficient transport to, and around the job site.
- While at the job site, or in the shop, all equipment is at your fingertips, making for a tidy work station.
- The jigs, routers, drill, drill bits, mortising machine, vacuum and all attachments, stay neatly in place while being transported.
- With the on-board vacuum, virtually dust free machining is obtained with the ability to clean out the lock recess and the immediate work area on completion. Automatic vacuum start when either the router or the mortising machine is started.
- Machine Trolley, manufactured from powdercoated steel tube.
- Pneumatic tyres for easy site movement, well balanced and with all equipment specially positioned.
- The additions of the Routing Jigs have proved highly valuable to the installers of chant™ and other proprietary hardware products, providing a professional finish to the installation.



## Trolley Power Tools

The equipment trolley shown above and on the cover, is fitted with Festool Routers, as generally sold in the USA. Different markets may use a single and/or different brand routers. There may also be variations in vacuum, attachments and Power Rail.

The standard power tools supplied are:

- Router: DeWalt DW621, with collets for  $\frac{3}{8}$ " and  $\frac{1}{2}$ " cutters, medium weight, plunge depth 45mm with vacuum attachment.
- Electric drill: DeWalt D21008-XL. 10mm keyless chuck, variable speed, 0–2500rpm, 550W  
or  
Makita 6408. 10mm keyless chuck, variable speed, 0–2500rpm, 530W  
or  
Makita DP4700. 13mm keyless chuck, variable speed, 0–550rpm, 510W, for heavy duty drilling operations.

## Dimensions

480mm wide, 600mm long, 1030 mm high (19" x 24" x 41")  
Approximate weight with above equipment: 40kg (89lbs.)

## Product Specifications

As chant™ product ranges continue to evolve, and the requirements of the construction industry expand, we reserve the right to change our specifications without notice. While we have taken every care in the preparation of this catalogue, we can take no responsibility for errors or omissions that have occurred.

If our products do not meet your site requirements, please forward your requests for us to evaluate customised solutions.

# chant™ Face Plate Routing Jig 6010



## Door Edge Extension Jig 6011

This jig clamps to the top or bottom of the door, extending the edge of the door so that the Face Plate Routing Jig can clamp onto it. This allows the template guide opening to extend beyond the end of the door allowing for the routing of chant™ Square Bolts or other proprietary flush bolts. The extension bar is 38mm (1½") wide.



- Designed for quick and accurate routing for the lock faceplate and marking of the spindle, cylinder and door hardware fixing holes.
- The Face Plate Routing Jig uses interchangeable router templates that simply snap into place, making multi-step mortising so easy. Templates are available, or can be custom made, to suit a wide range of mortise locks and faceplates such as Accurate, Baton, Baldwin, chant™, Legge, Lockwood, as well as numerous European locks.
- The optional Tubular Latch Jigs can be attached for drilling tubular latches and cross door drilling.
- Vertical height from the height locating and clamp centering block is 280mm (11") to the centreline, marked "C."
- The template guide opening is designed to suit a router guide, 6mm larger than the diameter of the router cutter being used to machine the lock faceplate recess.
- Auxiliary guide angles to suit router bases from 110mm (4¾") - 168mm (6⅝") in diameter, can be used when a faceplate template is not available. Set the angles to guide the baseplate of the router to machine the required cut out.
- Vertical bars for attaching the door hardware/lock cylinder marking templates. These are slotted at the top and bottom so that the backset position of the marking templates can be aligned perfectly with the lock spindle center in the left to right direction. It may be necessary to adjust these bars when machining a door with a bevelled edge.
- The auxiliary guide angles and the templates eliminate the possibility of the router cutter accidentally cutting an oversize recess.

- Door clamps hold the router plate square to the sides of the door.
- Clamps designed for door thickness: 30mm to 80mm (1¼" to 3⅛").
- Clamp adjustment left to right on the clamp center block allow the perfect parallel alignment of the template recess with the door faces.
- Our template guides are made from 6mm aluminium flat bar. They can be made in the joinery shop on CNC routers to our size specifications in other material, ie. acrylic sheet or high density board, for custom requirements.

### Operation

- Clamp the jig to the door against the bottom of the vertical locating clamp 6040, which has been set to the correct height for the lock/latch installation. The clamp has been previously used to position the mortise machine.
- Insert the correct faceplate template and door hardware/lock cylinder, marking templates into the jig body.
- Rout the faceplate recess to the required depth.
- Mark the appropriate holes on each side of the door with the marking punch.
- Remove the jig and drill the side holes in the door from each side with the appropriate size drills or cutters.
- Square the corners on the faceplate cut out with a standard or corner chisel, or knife.
- Vacuum clean the lock pocket.

This jig can be purchased as a separate item from the trolley.

chant™

## Lock Mortising Machine

6005 \* See note below

6006 \* See note below

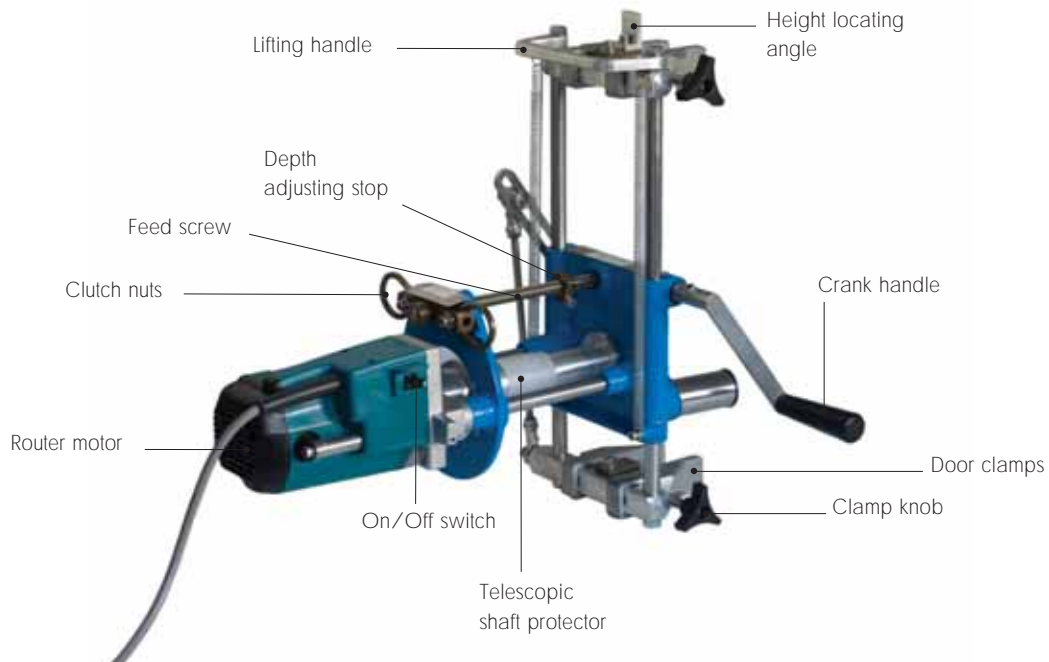

### Mortising Machine

\*6005 Machine fitted with a router shaft for router cutters with a ¼" UNF male threaded shank. Metric sizes, refer to page 9.

\*6006 Machine fitted with a router shaft for router cutters with a ¼" UNF female threaded bore. Imperial sizes, refer to page 9.

- Designed for quick, accurate and dust free mortising of doors from 30mm - 80mm thick. 1¼" to 3½"
- The Makita 3612C electronic speed controlled motor allows for low speed operations and is capable of cutting through metal clad fire doors with special cutters at the lowest speed of 9,000 rpm. Seek advice from Chant.
- Variable speed reduces the noise level while still maintaining optimum cutting efficiency.
- The machine is designed to be lifted by the lifting handle with the left hand, positioned on the door, and the clamp screws tightened with the right hand. Then operating the machine with the right hand on the crank handle.
- Self-centering door clamps with protective face pads. These are a generous length to avoid marking the door surface, and are machined with "toe-in" so that they grip at the tips first, then over their full length as the clamps tighten.

- Clamp adjustment left to right on the clamp centring block allows for the perfect parallel alignment of the machined recess with the door faces.
- Router shaft enclosed with telescopic sleeves for safety.
- Mortise cutter enclosed when on the door by the vacuum chamber.
- Shaving extraction system for operator safety, clean machine operation and work area.
- Mortise height adjustment: 40mm to 200mm (1½" to 7 7/8")
- Mortise depth adjustment: 125mm (5")
- Clamps designed for door thickness: 30mm to 80mm (1¼" to 3½").
- Cutter diameters available:  
16mm, 17mm, 18mm, 19mm, 20mm, 22mm, 25mm with ¼" UNF threaded shaft to screw into the end of the router shaft.  
5/8", ¾", 7/8", 1" with ¼" UNF threaded bore for the USA and some countries where this style of cutter is available. It requires the router shaft to have a ¼" UNF threaded stud protruding for the cutter to screw into. Refer to Mortise Shafts, Cutters and Accessories, page 8 for additional details.
- Weight: 13.4kg (30 lbs.)

The lock mortising machine can be purchased as a separate item from the trolley.

# chant™ Lock Mortising Machine

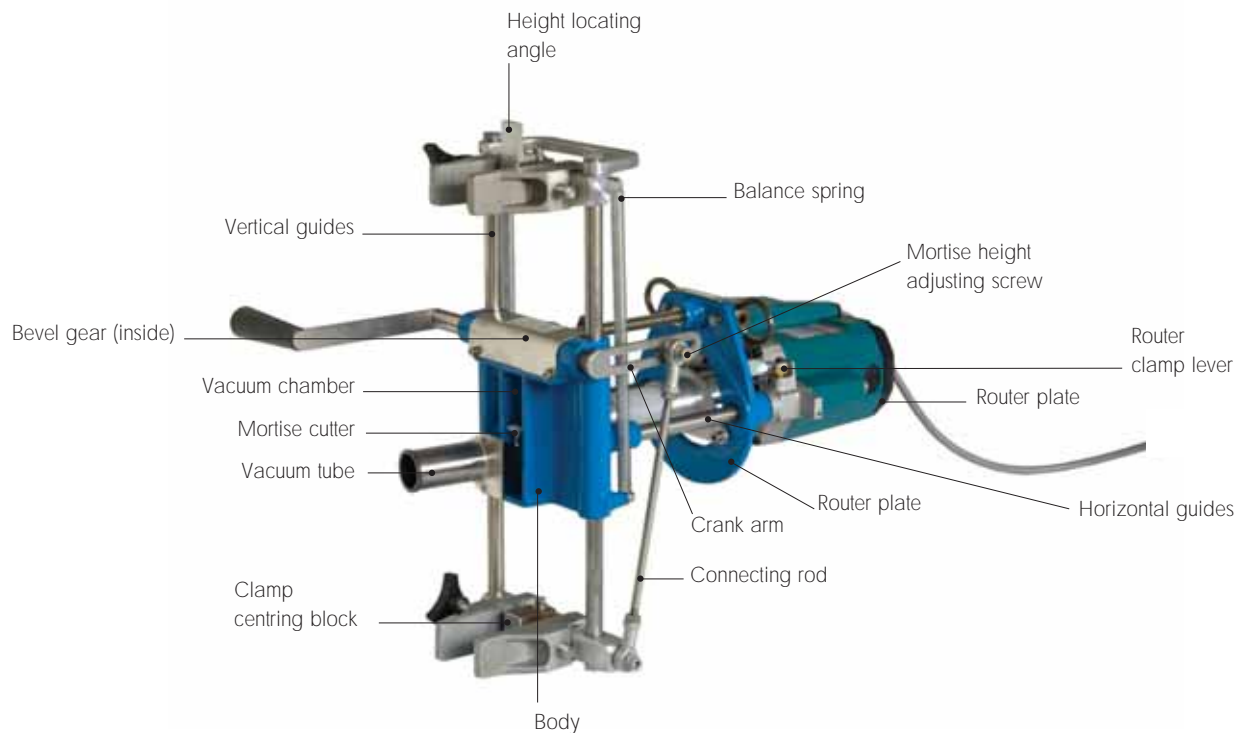

## Settings - Adjustment

1. Select and install the correct diameter mortise cutter to the machine for the lock being installed.
2. Calculate the correct MSH (Machine Setting Height) for the machine to be positioned on the door (see Positioning the Mortising Machine and Faceplate Jig on the Door for Various Locks).
3. Fasten the vertical locating clamp 6040 to the door with the bottom of the clamp flush with this mark.
4. Clamp the mortising machine to the door with the height locating angle against the underside of the vertical locating clamp.
5. Pull the clutch nuts apart to disengage the router motor from the feed screw and push the motor forward so that the cutter touches the door.
6. Lay the lock case being installed between the router plate and the depth adjusting stop. Release the clamp screw on the depth adjusting stop and rotate the stop along the feed shaft to provide a gap approximately 3mm or 1/8" between it and the lock case. Tighten the screw.
7. Return the router to the safety/start position.
8. Adjust the mortise height by releasing the mortise height adjusting screw and sliding the ball joint along the slot in the crank arm. It is graduated in mm for the clear rectangle that is machined, not including the radius at each end created by the cutter. Tighten the screw. Refer to Mortise Height Setting Dimension "X" on page 10.
9. Insert the vacuum hose.
10. Switch on the router motor and vacuum, or if the lock mortising machine is used in conjunction with the trolley, the vacuum will start automatically.
11. Crank the handle making the machine go up and down, while it self feeds into the door until the router head is close to the depth adjusting stop, approximately 1mm. There is no need to run into it. It is intended as an indicating stop only.
12. Stop the router motor.
13. Pull on the clutch nuts to release them from the feed screw and return the router head to the safety/start position.
14. Remove the vacuum hose and remove the machine from the door placing it back on the trolley for safe keeping.

chant™

## Jigs and Accessories

Tubular Latch Drill Jig  
6020

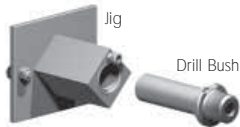

For a 24mm Auger Drill.  
Clips into the Faceplate Routing Jig.  
Drill Bushes  
6021 Ø10mm  
6022 Ø12mm  
6023 Ø19mm  
Drill bushes slide into the Tubular Latch Jig for drilling specific hole sizes. Can be used with a 10mm diameter extended drill, to cross drill through the door for a power transfer cable for an electric lock.

Drill Jig  
6026



Tubular Latch/Privacy Bolt Drill Jig for Baton Latch and Bolt.  
Uses 25mm Auger Drill  
Hole centres are 57mm (2¼").

Auger Drills  
6027 Ø24mm x 300mm  
6029 Ø25mm x 300mm

Tubular Latch Drill Jig  
6028



For a 25mm Auger Drill

Tubular Latch/Privacy Bolt Drill Jig for Baton Latch and Bolt  
6030



Clips into the Faceplate Routing Jig.

Uses Drill Bit 6037-1 or 6037-2  
1" diameter drill bit.  
(Templaco).

Hole centres are 57mm (2¼").

Baton Faceplate Template



6030-1  
57 x 25.4mm (2¼" x 1")  
(Baton Faceplate)

6030-2  
114 x 25.4mm (4½" x 1")  
(Baton, Combo Faceplate)

Clips into the Faceplate Routing Jig.

Baton Strike Templates



6030-3  
70 x 28mm (2¾" x 1⅜")  
(Standard Strike)

6030-4  
124 x 28mm (4⅞" x 1⅜")  
(Baton Combination Strike)

Clips into the Strike Plate Jig.

Drill Guide 6035



Used to provide 9.5mm (⅜") pilot holes, drilled from each side of the door for 60mm (2⅜") and 70mm (2¾") backset tubular latch and privacy bolt. These fasten onto the vertical bars on the faceplate routing jig.

Hole Saw 6036



54mm (2⅛") diameter hole saw with 9.5mm (⅜") drill to saw hole through the door. It is recommended to drill into the door part way from one side, and then drill from the other side to complete the hole. Using this hole saw, a 46mm plug is removed from the door with minimal sawdust. This avoids the total conversion of the wood removed to sawdust and chips when using a Forstner or similar bit.

Drill Bits



1" drill bit (Templaco).

6037-1 High Speed Steel Drill Bit  
6037-2 Carbide Tipped Drill Bit

Vertical Locating Clamp  
6040

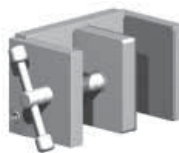

The underside of the locating clamp is positioned at the Machine Setting Height (MSH) established to locate the Lock Mortising Machine and the Face Plate Routing Jig, which are located against the underside of the Locating Clamp.

The clamp can also be used to locate the Universal Jig 6043 when used to machine a door for flush pulls at the same height on both sides of the door.  
Max door thickness: 80mm.

Strike Plate Jig  
6041



This jig clamps to the door jamb for routing of strike plates. It is adjustable left to right on the jamb to locate the template guide to position the strike plate for correct latching. This jig also allows for the use of an additional template to rout for the strike box (dust bucket) while the jig is set on the door. The adjustable clamping arrangement on this jig allows it to be used on door jambs with square faces, with or without draught seals, it is not suitable for doors with radiused architraves.  
Template size: 240 x 100mm.

Jamb Extension Bar  
6042



Extends the clamp on the strike plate jig for wide door frames or jambs.

Universal Jig  
6043



Adjustable backset.  
Used for: Flush Pulls, Privacy and Locking Flush Pulls, Extended Flush Sliding Bolts, Combination Pulls/Bolts.  
Adjustment of the jig from the door edge to centreline of the template is 40 – 68mm (1 1/2" – 2 11/16").  
Template size: 280 x 100mm.  
Max door thickness: 80mm.

Flush Sliding Bolt Jig  
6044



This jig is generally used on the top or bottom edges of the door to rout for a chant™ or similar sliding flush bolt. This jig can also be used with appropriate templates to prepare a door for Sun Valley Bronze gate latches. Clamped to the edge of the door, up against the 6040 Vertical Locating Clamp, routing can be done on one side of the door. Then the jig is removed, rolled over, and clamped on the opposite face up against the Vertical Locating Clamp, the template changed for the different routing detail and routed.  
Template size: 280 x 100mm.  
Max door thickness: 80mm.

Edge Jig  
6045

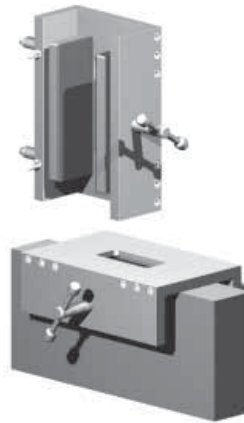

Used to rout the vertical edge of the door for chant™ 1500 Edge Pulls. Also used to rout the guide plate recess on the top and bottom of a door for chant™ 2031, etc.. Flush Sliding Bolts and Tubular Latch Faceplates that need to be positioned close to the leading edge of the door.  
Template size: 120mm x 50mm  
Jig length: 200mm  
Max door thickness: 80mm

Edge Jig fitted to the top of a door with template inserted.

Drill Guide  
6045-1



To drill for a Pull Latch with a 25mm auger drill. Fastens to the face of the 6045 Edge Jig.

Sliding Bolt, Rod Drill Jig  
6046 Ø12.7mm (1/2")  
6048 Ø10mm

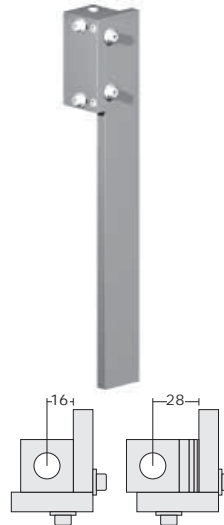

This jig is used to drill up or down the door for the operating rod of a chant™ Sliding Bolt or to drill a hole across the door for power transfer cables. Drill guide sizes are 12.7mm (1/2") or 10mm diameter. A range of packing shims is provided (1, 2, 3 and 6mm). These pack the drill guide block from 16mm (5/8") from the door face, with no packers, to 28mm (1 1/8") from the door face. Clamp the jig to the door with standard sliding or "G" clamps.

Extended Drill  
6046-1  
6046-2  
6048-1

Ø12.7mm (1/2") x 600mm (24")  
Ø12.7mm (1/2") x 1000mm (39")  
Ø10mm x 1000mm (39")

Strike Plate Jig  
6047



For use on door jambs with radiused architraves where Strike Plate Jig 6041 will not clamp. This jig is positioned and nailed to the jamb.

Corner Chisel  
6057



Fits 25.4mm (1") wide faceplate recesses. Used to chisel the radiussed corner left by the Faceplate Router Cutter into a square corner.

Lock Mortising  
Machine Stand  
6058

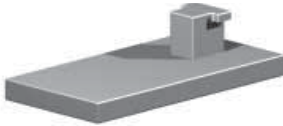

The bottom clamps on the mortising machine hook under the protrusions on the base block, and are clamped to the block so that the machine stands erect for servicing or changing cutters.

Template Box  
6059

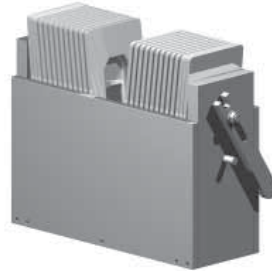

Stores standard templates, 100mm x 280mm, for easy sorting and retrieval. Aluminium base plate machined with 24 slots allows templates to lean in either direction, allowing easy viewing of the template number and product description. Carry handle folds down for access to the templates.

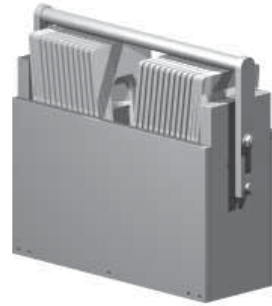

#### Master / Slave Power Rail

Designed for use on the Door Machining Equipment Trolley. It provides automatic switching, on and off, of the vacuum cleaner when the Lock Mortising Machine or the separate Router are switched on or off.

The standard Power Rails are equipped as follows:

- Thermal overload
- Two master socket outlets
- One slave socket outlet
- One standard socket outlet (not controlled)
- Switch to manually override the slave socket outlet, without it being switched by the master socket outlets.

Available as an accessory, or stand alone product in the following configurations for different countries.

6100 New Zealand / Australia Socket Outlets, 230V, 10A

6110 Middle East / UK Socket Outlets, 230V, 10A

6120 USA Socket Outlets, 110V, 15A

Variations can be made to order, refer to Chant.



# chant™

## Mortise Shafts, Cutters and Accessories

Router Shaft  
6060 (for Lock Mortising  
Machine 6005)



¼" UNF female thread  
for 6061 – 6067 cutters.

Mortise Cutter  
Available only from Chant  
with the ¼" UNF male  
threaded shank.



- 6061 Ø16mm
- 6062 Ø17mm
- 6063 Ø18mm
- 6064 Ø19mm
- 6065 Ø20mm
- 6066 Ø22mm
- 6067 Ø25mm

Router Shaft  
6070 (for Lock Mortising  
Machine 6006)



¼" UNF male thread. For  
6071 - 6074 cutters, for the  
USA and other countries  
where the router cutters below  
are readily available.

Mortise Cutter



- 6071 Ø 5/8"
- 6072 Ø 3/4"
- 6073 Ø 7/8"
- 6074 Ø 1"

Router Cutter  
6080



Ø 3/8" x 80mm long

Router Cutter  
6082



Ø 3/8" x 80mm long  
with Ø 5/16" shank for  
Festool 1010 Router.

Router Pilot Guide

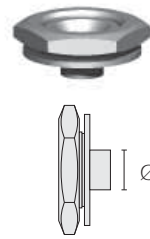

The guide is 6mm greater  
in diameter than the router  
cutter being used. Hexagon  
nut to aid tightening. It will  
generally fit into routers that  
have an adaptor with a  
30mm bore to accept other  
proprietary pilot guides.

- 6090  
Ø12.4mm for ¼" cutter (6.4mm)
- 6091  
Ø15.5mm for 3/8" cutter (9.5mm)
- 6092  
Ø18.7mm for ½" cutter (12.7mm)
- 6093  
Ø12mm for 6mm cutter

For smaller guides to provide an oversize cutout, or larger  
guides to provide a smaller cutout, specify diameter required  
and order from chant™.

Adaptor Plate  
6099 - 1



Adapts the router pilot guide  
to the base of a DeWalt  
621 router.

Chant also manufacture a variety of special jigs that assist in  
the routing of doors and frames for other proprietary hardware.  
They include sliding door handles, flush bolts and electric strikes  
etc. If you have custom requirements, we would be pleased to  
review and create solutions.

chant™

## Positioning the Mortising Machine and Faceplate Jig on the Door

for Various Locks. Use these examples to calculate the Machine Setting Height (MSH) for other locks.

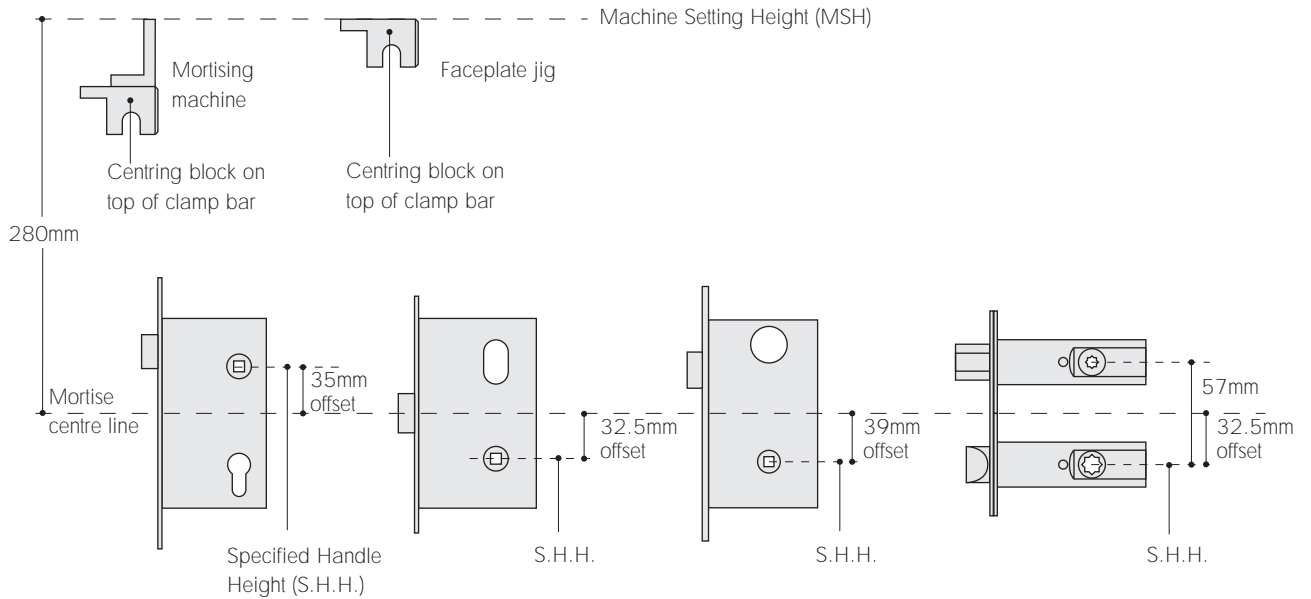

- chant™ 1000-1004 Mortise Locks
- Lever above the mortise centre line.
- Machine setting height (MSH) is:  $(S.H.H. - 35mm) + 280mm$
- Legge 990 Lock
- Lever below the mortise centre line
- Machine setting height (MSH) is:  $(S.H.H. + 32.5mm) + 280mm$
- Accurate 8000, 8500, 9000, 9100 Locks
- Lever below the mortise centre line
- Machine setting height (MSH) is:  $(S.H.H. + 39mm) + 280mm$
- Baton privacy/deadbolt and tubular latch using chant™ 6026 or 6030 Drill Jig and Faceplate Template
- Machine setting height (MSH) is:  $(S.H.H. + 32.5mm) + 280mm$

## Setting Calculation for other Euro Profile Locks, Hafele, CISA etc.

For other Euro profile cylinder locks it is necessary to measure and calculate the offset dimension from the spindle centre line to the centre line of the case, which becomes the mortise centre line.

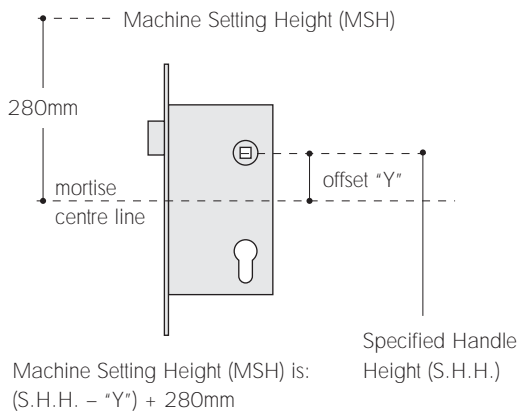

## Mortise Height Setting Dimension "X".

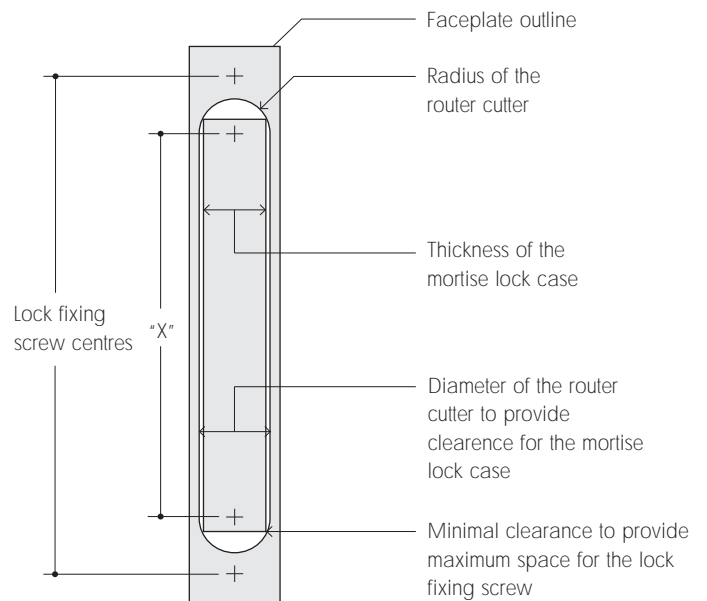

"X" is the height setting, to be set on the crank arm on the lock mortising machine. Dimension "X" is approximately 5-10mm ( $\frac{3}{16}$ " -  $\frac{3}{8}$ " ) less than the height of the lock case in most situations. It is recommended to trial mortise, trial fit the lock, adjust and remortise the door if the lock does not fit.

# Operating and Safety Instructions

Read the instructions of the proprietary tool that is provided on the trolley in conjunction with these instructions.

## Safety instructions

1. Always wear eye protection.
2. Keep children away. Always keep visitors at a safe distance from work areas.
3. Keep work areas clean.
4. Do not wear loose clothing which can become entangled in machine. Wear protective hair covering to contain long hair.

## Work area

1. Keep work area well lit, clean and tidy. Cluttered and dark areas increase the chance of accidents.
2. Do not operate power tools in potentially explosive atmospheres, such as in the presence of flammable liquids, gases or dust. Power tools generate sparks which may ignite dust or fumes.
3. Keep children and bystanders well away during power tool operations. Distractions can cause you to lose control.

## Electrical safety

1. Power tool plugs must always match the outlet. Do not modify the plug in any way. Do not use any adaptor plugs with earthed (grounded) power tools. Unmodified plugs and matching outlets reduce the risk of electric shock.
2. Avoid body contact with earthed or grounded surfaces such as pipes, radiators, ranges and refrigerators. If your body is earthed or grounded there is an increased risk of electric shock.
3. Do not expose power tools to rain or other wet conditions. Water entering a power tool will damage it and increase the risk of electric shock.
4. Do not abuse the cord. Do not use the cord for carrying, pulling or unplugging the power tool. Keep cord away from heat, oil, sharp edges or moving parts. Damaged or entangled cords increase the risk of electric shock.
5. When operating a power tool outdoors, use an extension cord suitable for outdoor use. Use of a cord suitable for outdoor use reduces the risk of electric shock.

## Personal safety

1. Remain alert, watch what you are doing and use common sense when operating a power tool. Do not use a power tool when tired or under the influence of drugs, alcohol or medication. A moment of inattention while operating power tools may result in serious injury.
2. Use safety equipment. Always wear eye protection.
3. Avoid accidental starting. Before plugging in ensure any switches are in the off position.
4. Remove any adjusting key or wrench before turning on the power tool. A wrench or a key left attached to a rotating part of the power tool may result in injury.
5. Dress properly. Do not wear loose clothing or jewellery. Keep your hair, clothing and gloves away from all moving parts.

6. If devices are provided for the connection of dust extraction and collection facilities, always ensure these are connected and properly used.

## Power tool use and care

1. Do not force a power tool.
2. Disconnect the plug from the power source before making any adjustments, changing accessories, or storing power tools.
3. Maintain power tools. Check for misalignment or binding of moving parts.
4. Keep cutting tools clean and sharp.
5. Use the power tool, accessories and tool bits etc., in accordance with these instructions and in the manner intended for the particular type of power tool.

## Intended use

This equipment is designed for routing wood. Aluminium can also be processed with corresponding cutters.

## Tool-specific safety rules

Do not exceed the maximum speed specified on the tool and/or keep to the speed range.

## Machine settings

Always remove the power supply plug from the socket before carrying out any work on the machine.

## Mortising machine and routers

Always connect the machine to the dust extractor.

## Maintenance and care

Always remove the power supply plug from the socket before carrying out any work on the machine.

## Risk of electric shock

Never grasp the mains plug with wet hands. Check the connection lead and mains plug for damage before each use. Have a damaged connection lead replaced immediately by an authorised Customer Service point or by an electrician.

## General safety notes

The appliance is not intended for use by young children or infirm persons. Young children should be supervised to ensure that they do not play with the appliance. Never leave the machine unattended if the master switch is on.

## Finish operation

Empty the vacuum cleaner of sawdust.

## about chant™

chant™ is a manufacturer of exclusive hardware for residential, commercial and marine applications.

Custom designs, finishes and variations to existing products are also part of the chant™ offering, providing solutions for architects and developers where standard products do not fit on-site requirements.

The manufacturing team, artisans in their own right, and the suppliers to the company, all contribute to the creation of these unique products from New Zealand.

Our hardware is sought after by architects, developers and owners of exclusive residential and commercial properties and has been the preferred choice of internationally recognised hotels such as the Fairmont in Dubai, Regency Parkway in the Philippines and the Orchard Scott in Singapore.

The chant™ products are beautifully designed, functional, precision-engineered and very much 'in touch' with contemporary architecture and interior design. Please visit our website for more information.

*Graham, Nathan and Byron Chant*



[www.chantintouch.com](http://www.chantintouch.com)

designed  
and manufactured by:  
chant productions limited  
8/136 marua road, ellerslie  
auckland, new zealand  
telephone: + 64 9 526 4048  
facsimile: + 64 9 526 4049  
email: [sales@chantintouch.com](mailto:sales@chantintouch.com)  
[www.chantintouch.com](http://www.chantintouch.com)

usa distributor:  
in touch international inc.  
42-240 greenway, suite D  
palm desert, CA 92211  
united states of america  
telephone: + 1 760 568 9662  
facsimile: + 1 760 341 0210  
email: [info@intouchhardware.com](mailto:info@intouchhardware.com)  
[www.intouchhardware.com](http://www.intouchhardware.com)