

Privacy Flush Pull 1601TE

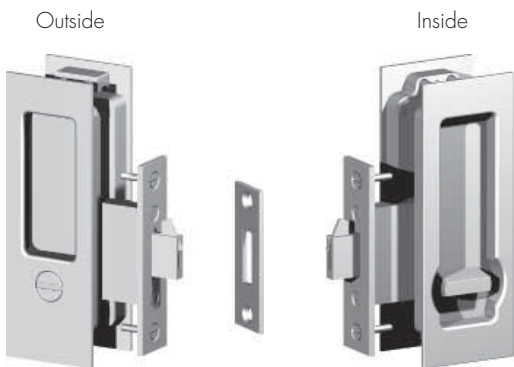

Privacy Sliding Door Lock 1647



Privacy Sliding Door Lock 1647
(5mm Square Spindle)

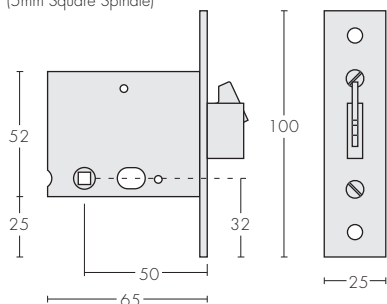

Strike 1648

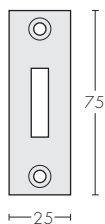

Privacy Flush Pulls

Designed to fit back to back on wood sliding doors of 35mm, minimum thickness.

The back set of the flush pull centreline is 50mm.

The outside flush pull is fastened into its recess by tie screws into the back of the flush pull body, through mounting blocks on the inside of the door. The inside flush pull is then inserted into its recess on the inside with a spindle passing through the lock into the outside emergency flush pull. It is then fastened to the mounting blocks by a socket set screw in the top of the finger recess. This is our "C" Fixing.

Door thickness must be specified so the correct length screws and spindle can be provided.

The Pulls are available in the following configurations:

- Turn and Emergency TE
- Turn and Turn TT

Style Options:

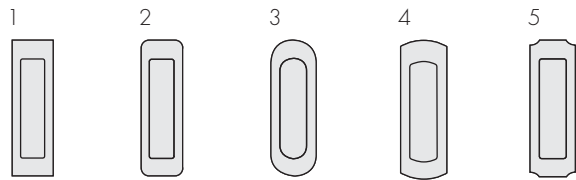

Privacy Flush Pull Sizes and Code Numbers

Overall Size	Style Option and Code Number				
	1	2	3	4	5
50 x 150	1601	1602	1603	1604	1605
50 x 175	1611	1612	1613	1614	1615
50 x 200	1621	1622	1623	1624	1625
50 x 250	1631	1632	1633	1634	1635
50 x 300	1641	1642	1643	1644	1645

To specify: (example)

Code Number	Turn Option	Door Thickness	Finish
1611	TE or TT	40mm	SCPV

Privacy Sliding Door Lock 1647

Strike 1648

Escutcheon Fixing Kit 1649

Designed as a light duty lock with a thin case, 9.5mm, to fit between our flush pulls on doors of minimum 35mm thickness.

It can also be used in thin door applications, typically marine, with surface or back to back mounted turn escutcheons, ie 3401 Thumb Turn and 3402 Emergency Turn etc.

The lock case has through fixing holes at 35mm to 41mm centres horizontally about the spindle centreline for a back to back Escutcheon Fixing Kit, 1649. Specify door thickness when ordering.

To assist with installation, refer to [Mortising Machine 6005](#), [Faceplate Routing Jig 6010](#) and [Universal Jig 6043](#) in the [Door Machining Equipment Section](#) in this catalogue or on the website.