

## Two Point Latches and Bolts

This series of mortise locks and latches are designed primarily for wood, double entrance doors. The doors can then be opened simultaneously to provide a grand entrance, opening the doors 'the way the butler used to'.

The doors can be rebated or square edge and must be custom built to provide a recess to allow for the internal vertical rods to operate the latch or locking bolt. This is an alternative to exposed, surface espagnolette rods.

These mechanisms can be used with the following options of door hardware for the lockable versions:

- Lever handles outside and inside
- Lock cylinder on one, or both door leaves, or neither side of either door
- Cylinder or thumb turn on the inside
- Pull handles on the outside with no access; lever handle surface mounted on the inside, with lock cylinder, or turn, or neither function.

This type of "door set" is custom designed because of the various options with doors and operating door hardware, as they are site specific. Consult chant™ with your requirements.

The mortise locks have a 3mm thick faceplate and a 3mm thick mounting plate to secure the lock in place. When fitted to rebated doors, the mounting plate is against the rebate to minimise the visual offset of the lever handle from the edge of the door, on both sides of the door.

On square edge doors, a brush type weather seal can be used as a draught strip to fill the gap between the doors. This requires dimensional accuracy on the installation of the doors, and allowance for the possible expansion and contraction of the doors due to temperature and humidity changes.

The lever handle back set from the faceplate of the lock is 60mm, and the bolt or rod, 45mm.

### General Installation

1. The mortised lock or latch mechanism is fitted to the door in a standard mortise pocket and faceplate recess.
2. The pull rods for the latches or bolts are cut to length to a calculation of door size and handle height.
3. The pull rods are then secured into the lock bolt or tubular latch with thread locking compound.
4. Anti rattle discs are provided that can be cut down to suit the pull rod trench size, and guide the pull rods into the lock.
5. The assembly is then inserted into the prepared rod hole and screwed into the lock or latch body, until the correct vertical adjustment is achieved.
6. The faceplate of the tubular latch will drop into its prepared recess and is then fastened with two screws, or the guide plate fitted over the locking bolt. The guide plate has a slotted hole to suit the round bolt which has two flat surfaces to prevent the bolt from rotating.

### Lever Handles on Roses and Plates

All chant™ lever handles on the various rose types, and back plates from the following group can be used with the 1150, 1151, 1152 and 1153 Latches/Locks.

- 32mm wide plates 30 and 40 groups.
- 38mm wide plates 110 and 130 groups.
- 44mm wide plates 250 and 260 groups.
- 50mm wide plates 310 and 320 groups.

When the Locks in Options C and D are used, the inside lever handle plate requires the bolt release button to be fitted, specify "R" after the plate code number when ordering the handles.

### Door Construction

When these bolts are fitted to a wood door, it must be custom built, as the stile requires a trench, vertically positioned to allow the bolt to operate. The position of the trench and lock will depend on the construction of the door, particularly in relation to tennon joints in the corners. The lock may need to be off centre in the stile.

Option A: Split stile, trenched before the two sections are glued together. Alternative join line shown as dotted line.



Option B: Trenched from the edge and back-filled with an insert.



Option C: Trenched from the front or back face and back filled with an insert.

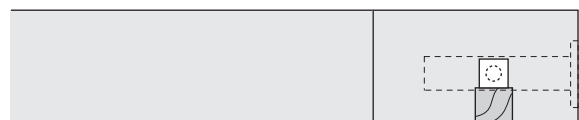

## Options:

### A. Two Point Latch and Bolt/Lockable 1150

Used when there is no sill at the bottom of the door. The latch secures the door at the top and the bolt fits into an elongated dust socket or strike on the floor. When the lever is fully operated, both latch and bolt withdraw. The bolt 'catches' and stays retracted in the mortise lock, allowing the door to be opened. When the levers are released, the bolt, which is retracted, will not scrape on the floor. When the door is shut and latches at the top, the thumb turn or key can be turned to release the bolt and secure the door. Further turning of the key locks the lever handles. This feature can also be used to fasten the door in the open position with the bolt secured in a second dust socket or strike.

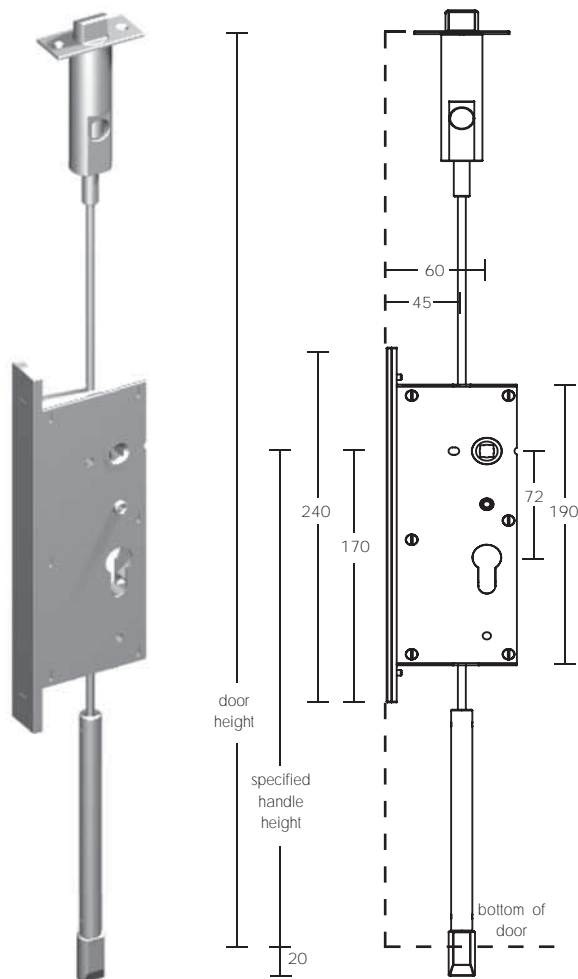

### B. Two Point Latch/Lockable 1151

Used when there is a sill at the bottom of the door. The latches secure the door at the top and the bottom. When the lever is operated, both latches withdraw. When the door is shut and the latches secure the door, the thumb turn or key can be turned to lock the lever handle and secure the door.



## Dust Sockets

Refer to Dust Sockets in the Accessories Section for full details. These are designed with a round ended, elongated opening so that there is tolerance for installation and any expansion or shrinkage in wood doors.

## Latch Strikes

Refer to Mortise Latches in this section for full details of strike options.

### C. Two Point Latch and Bolt, Non locking 1152

Similar to the 1150 and 1151 lock but without the Euro Profile Cylinder barrel. Used in applications where pull handles are on the outside of the door, with no entry, opening from inside only.

Used when there is no sill at the bottom of the door. The latch secures the door at the top and the bolt fits into an elongated dust socket or strike on the floor. When the lever is fully operated, both latch and bolt withdraw. The bolt 'catches' and stays retracted in the mortise lock, allowing the door to be opened. When the levers are released, the bolt, which is retracted, will not scrape on the floor. When the door is shut and latches at the top, the bolt release button can be pushed to release the bolt and secure the door. This feature can also be used to fasten the door in the open position with the bolt secured in a second dust socket or strike.

The door self latches when closing.

With this two point latch and bolt, the inside lever handle plate requires the bolt release button to be fitted, specify "R" after the plate code number when ordering the handles.

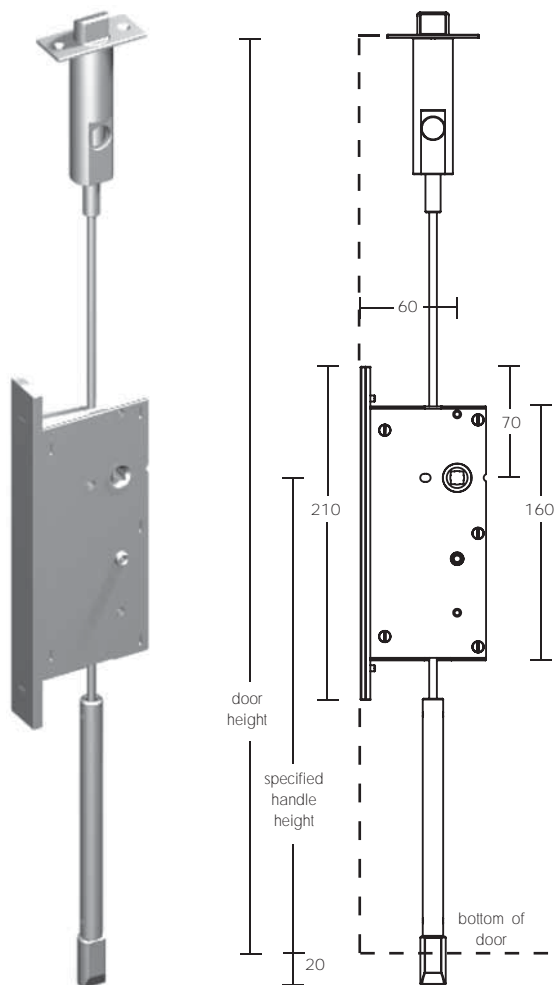

### D. Two Point Latch, Non locking 1153

Used when there is a sill at the bottom of the door. The lever handles when operated, withdraws both latches allowing the door to be opened. The door self latches when closing.

The 1152 and the 1153 locks can be use on the secondary door of a pair of opening doors as they do not generally need a full locking function. Suitable when operated by a lever handle on the inside only.

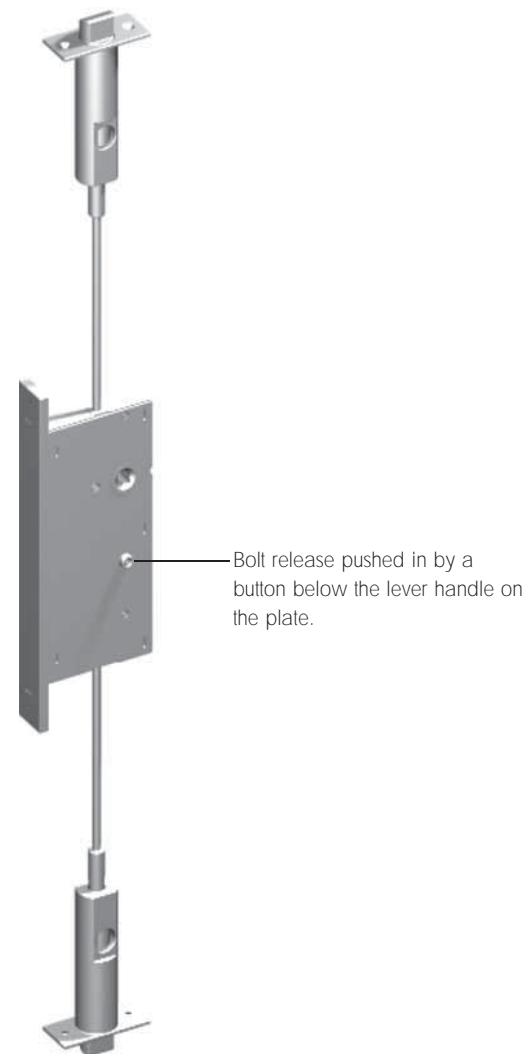

### E. One Point Latch 1154-1

This unique cylindrical latch mechanism is designed to fit into a specially made door, with a hole down the door for the tubular latch pull rod.

The cylindrical latch mechanism fits into a 44mm ( $1\frac{3}{4}$ " ) diameter circular hole, either partially or fully through the door. It is secured into the recess with 4 socket set screws to key it into the door. The hole must be bored accurately with a good quality hole saw, perpendicular to the surface of the door. Back to back handles are tie screw fixed through the mechanism. When the levers are operated, the latch retracts.

The mechanism is suitable for;

- A single handle on one side, which is surface fixed to the mechanism. In this application the latch mechanism is fitted into a blind hole from the operating side.
- Handles both sides, tie-screwed through the door and mechanism.
- A single latch at the top only or can be turned 90 degrees with the pull rod and tubular latch horizontal.
- Horizontal fixing of the lever handle is at 38mm centres, suitable for any chant lever handles on rose.
- The latch mechanism is machined from solid brass.
- Spindle size 8mm.

The mechanism shown below has a pair of Delta Handles on rose.



### F. Two Point Latch 1154-2

Two Point Latch shown below. General details as previously.

